

A **biomass-based power plant** is a type of renewable energy system that generates electricity by using **organic materials (biomass)** as fuel. Biomass can include agricultural residues, wood and forestry waste, animal dung, municipal solid waste, or specially grown energy crops.

Examples of Biomass Fuels Used in India

Biomass Type	Source
Bagasse	Sugar mills
Rice Husk	Rice mills
Sawdust & Wood Chips	Timber industry
Poultry Litter & Cow Dung	Animal farms
Municipal Solid Waste	Urban garbage
Coconut Shells	Coconut industry

Properties of Wood Chips (as a Biomass Fuel)

Wood chips are one of the most commonly used solid biomass fuels in small and medium-scale biomass power plants, boilers, and gasifiers. Their properties affect combustion efficiency, storage, handling, and energy output.

Physical Properties

Property	Typical Value / Description
Size	5–50 mm (depends on chipper type; smaller for boilers, larger for gasifiers)
Shape	Irregular, flat pieces with a high surface-area-to-volume ratio
Bulk Density	150–350 kg/m ³ (fresh), 180–450 kg/m ³ (dry & compacted)
Moisture Content	20%–60% (fresh wood), 10%–20% (air-dried), <10% (kiln-dried)
Porosity	High (allows airflow, helps drying)
Ash Content	0.5%–3% (varies by species and bark content)

Combustion & Energy Properties

Property	Typical Value / Characteristics
Calorific Value (Higher Heating Value - HHV)	18–20 MJ/kg (bone dry)

Property	Typical Value / Characteristics
Ignition Temperature	~250–300 °C
Fixed Carbon	15–20%
Ash Fusion Temperature	1000–1200 °C (prevents slagging in boilers)
Energy Density	Lower than coal due to high moisture & low bulk density

Chemical Properties

Component	Typical Percentage (Dry Basis)
Carbon (C)	45–50%
Hydrogen (H)	5–6%
Oxygen (O)	40–45%
Nitrogen (N)	<1%
Sulphur (S)	<0.05% (very low → less SO ₂ emissions)
Chlorine (Cl)	<0.05% (low → less corrosion)

Storage & Handling Characteristics

✓ Advantages:

- Easy to chip and store in large volumes
- Free-flowing, usable in automatic feeding systems
- Less dusty compared to sawdust or pellets

□ Concerns:

- High moisture can cause fungal growth, decay, and self-heating
- May produce mold spores → health hazard in closed storage
- Bulk storage requires proper ventilation to avoid fire risk

Properties of Bagasse (Sugarcane Residue Used as Biomass Fuel)

Bagasse is the fibrous material left after crushing sugarcane to extract juice. It is widely used as fuel in **cogeneration (steam + electricity) power plants** in sugar mills, paper mills, and biomass boilers.

Physical Properties

Property	Typical Value / Description
Appearance	Fibrous, light, spongy residue
Fiber Length	1–5 mm (depends on milling process)
Moisture Content (as received)	45–55% (fresh from mill)
Moisture Content (dry basis)	<10% (when stored & dried)
Ash Content	1.5–4% (low ash → good fuel)
Color	Brownish / yellowish grey

Combustion & Energy Properties

Property	Typical Value
Calorific Value (HHV, Dry Basis)	17–19 MJ/kg
Calorific Value (As Received, 50% moisture)	7–10 MJ/kg
Fixed Carbon	15–20%
Ash Fusion Temperature	900–1000 °C
Ignition Temperature	~250–300 °C
Energy Density	Low (because of high moisture and low bulk density)

Chemical Properties (Typical Composition, Dry Basis)

Element / Component	Percentage
Carbon (C)	42–45%
Hydrogen (H)	5–6%
Oxygen (O)	45–50%
Nitrogen (N)	<0.5%
Sulphur (S)	<0.1%
Chlorine (Cl)	<0.1%
Silica (SiO ₂)	1–2% (comes from soil, cane skin)

Storage & Handling Characteristics

✓ Advantages:

- Readily available in sugar factories
- Can be used immediately as fuel (no drying needed)
- Can be stored in baled or loose form
- Easy to burn in specially designed boilers

□ Concerns:

- High moisture content → low calorific value
- Susceptible to microbial decay, biogas formation in wet storage
- Risk of **self-ignition** in bulk piles due to fermentation heat
- Dust from dry bagasse can be explosive in air

Properties of Rice Husk (Agro-Residue Biomass Fuel)

Rice husk (also called **rice hull**) is the outer protective covering of rice grains, removed during milling. It is widely used as a biomass fuel in boilers, gasifiers, and power plants, especially in rice-producing countries like India.

Physical Properties

Property	Typical Value / Description
Appearance	Thin, flaky, lightweight outer shell
Particle Size	2–5 mm (irregular shape)
Moisture Content (as received)	8–12% (naturally dry)
Color	Light brown to grey
Ash Content	15–25% (very high compared to other biomass)

Combustion & Energy Properties

Property	Typical Value
Calorific Value (Dry Basis)	14–16 MJ/kg

Property	Typical Value
Fixed Carbon	15–20%
Ash Fusion Temperature	1300–1500 °C (can cause clinker if boiler is not designed properly)
Ignition Temperature	~250–300 °C
Energy Density	Low, because of low bulk density

Chemical Properties (Dry Basis)

Component	Percentage
Carbon (C)	35–38%
Hydrogen (H)	4–5%
Oxygen (O)	38–42%
Nitrogen (N)	<1%
Sulphur (S)	<0.1% (very low SO ₂ emission)
Silica (SiO ₂) in Ash	80–90% (main cause of high ash)

Storage & Handling Characteristics

✓ Advantages

- Naturally dry (no drying cost)
- Easily available near rice mills
- Light and easy to transport in bulk
- Does not decay biologically quickly

□ Disadvantages

- Very low bulk density → more volume needed for same energy
- High ash content → more ash disposal, clinker formation in boilers
- Silica-rich ash may cause abrasion in feeding systems
- Dust can be a respiratory hazard if not controlled

Properties of Municipal Solid Waste (MSW)

(Also called municipal garbage, household waste, city waste, urban solid waste)

Municipal Solid Waste (MSW) is the mixture of discarded materials generated by households, commercial establishments, offices, institutions, markets, and sometimes small industries. It is **heterogeneous** and its properties vary based on population, lifestyle, income level, and waste management system of the city.

Physical Properties

Property	Typical Range / Description
Density (Loose / Collected)	100–600 kg/m ³ (India avg: 300–450 kg/m ³)
Moisture Content	20–60% (high in developing countries due to food waste)
Particle Size	5–300 mm (highly non-uniform)
Color & Texture	Mixed – organic, plastic, paper, metals, fabric etc.
Calorific Value (As Collected)	800–1500 kcal/kg (3.3–6.3 MJ/kg)
Calorific Value (After Segregation / RDF)	2500–3500 kcal/kg (10–15 MJ/kg)
Biodegradable Fraction	40–60% (higher in India due to food/yard waste)
Non-biodegradable Fraction	30–50% (plastic, glass, metals, rubber, textiles)
Inert Content (sand, stones, dust)	5–10% in urban waste, can be higher in slum areas

Chemical Properties (Typical Composition by Weight)

(Varies by country and level of segregation)

Component	% by Weight (Typical Indian MSW)
Carbon (C)	25–35%
Hydrogen (H)	3–6%
Oxygen (O)	15–20%
Nitrogen (N)	0.3–0.6%
Sulphur (S)	0.1–0.4%
Chlorine (Cl)	0.3–0.8%
Ash Content	15–30%

Energy & Combustion Properties

Property	Value
Energy Content (Raw MSW)	4–8 MJ/kg (low due to moisture)
Energy Content (RDF Pellets/Briquettes)	10–18 MJ/kg
Ash Content	20–30% (higher than biomass)
Suitability for Combustion	Needs segregation or RDF conversion

RDF = **Refuse Derived Fuel** (after removing inerts, metals, wet waste).

Typical Composition of MSW in India

Component	Approx %
Food & Organic Waste	40–55%
Paper & Cardboard	5–10%
Plastics	6–12%
Glass & Ceramics	2–5%
Metals	1–4%
Textiles & Rubber	2–6%
Inert (Soil, dust, stones)	15–25%

Properties of Jatropha (as a Biofuel Crop and Biomass Source)

Jatropha curcas is a drought-resistant, oil-bearing plant widely used for **biodiesel production** and **biomass energy**. It grows in marginal land, requires low nutrients, and is considered a non-food energy crop.

Physical Properties of Jatropha Seeds

Property	Typical Value / Description
Seed Size	15–20 mm long, oval shape
Seed Weight	0.5–0.8 g per seed
Seed Husk (%)	35–40% of total seed weight
Oil Content (by weight)	30–40% (varies with variety & soil)
Bulk Density (Seeds)	550–600 kg/m ³
Moisture Content (fresh seeds)	6–12%

Chemical Properties of Jatropha Oil (for Biodiesel)

Property	Typical Value
Calorific Value (Oil)	39–40 MJ/kg
Viscosity (at 40°C)	35–45 cSt (needs transesterification for biodiesel)
Density	0.91–0.92 g/cm ³
Free Fatty Acid (FFA)	3–15% (high FFA → acid esterification needed)
Iodine Value	90–105 mg KOH/g (unsaturated content)
Cetane Number (biodiesel)	50–55 (good for diesel engines)
Flash Point	240–260 °C

Toxicity & Limitations

- Seeds and oil contain **phorbol esters** → toxic, not edible.
- Seed cake cannot be used as animal feed without detoxification.
- Yield depends on rainfall and soil fertility; commercial plantations need irrigation.

Properties of Biodiesel

Biodiesel is a **renewable, biodegradable fuel** made from vegetable oils, animal fats, or used cooking oil through a process called **transesterification**.

Physical & Chemical Properties

Property	Typical Value (B100 – pure biodiesel)
Density @ 15°C	0.86 – 0.90 g/cm ³
Kinematic Viscosity @ 40°C	4 – 6 cSt
Flash Point	> 130°C (much safer than diesel)
Cetane Number	50 – 65 (better ignition quality than diesel)
Calorific Value	37 – 40 MJ/kg (≈ 10% lower than diesel)
Cloud Point	2°C to 12°C (varies with feedstock, higher than diesel)
Pour Point	–5°C to 10°C
Oxygen Content	8 – 12% (helps cleaner combustion)
Sulphur Content	< 0.001% (almost zero SO ₂ emission)
Carbon Residue	< 0.05%

Advantages

- Renewable & biodegradable
- Lower CO, HC, SO₂, and particulate emissions
- Higher flash point → safer to store
- Good lubricity → protects engine parts

□ Limitations

- Slightly lower energy content → small drop in engine power
- Poor cold flow behavior (gels in low temperature)
- Can attack rubber seals in old engines

Properties of Gobar Gas (Biogas from Cow Dung)

"Gobar gas" is the common name in India for **biogas produced from anaerobic digestion of cow dung**, mixed with water in a biogas plant.

Composition (Typical % by Volume)

Gas Component	Percentage
Methane (CH ₄)	50 – 65%
Carbon Dioxide (CO ₂)	30 – 40%
Water Vapor (H ₂ O)	2 – 7%
Hydrogen Sulphide (H ₂ S)	0.1 – 0.3% (corrosive, must be removed)
Nitrogen (N ₂)	0 – 1%
Oxygen (O ₂)	~0% (anaerobic process)

Energy Properties

Property	Value
Calorific Value (Raw Biogas)	18 – 24 MJ/m ³
Energy Content (Methane Only)	35.8 MJ/m ³
Flammability Limit	6–12% methane in air
Auto-ignition Temperature	~ 600°C

If upgraded to >95% methane, it becomes **bio-CNG** (vehicle fuel).

Physical Properties

Property	Description
State	Colorless gas
Odor	Rotten egg smell (due to H ₂ S)
Density	1.2–1.3 kg/m ³ (lighter than air when methane-rich)
pH of slurry	6.8 – 7.5 (neutral to slightly alkaline)

Comparison Summary

Property	Biodiesel	Gobar Gas (Biogas)
State	Liquid	Gas
Main Fuel Content	Fatty acid methyl esters	Methane
Source	Vegetable oil / animal fat	Cow dung, organic waste
Use	Diesel engine fuel (liquid fuel)	Cooking, electricity, engines (gas fuel)
Calorific Value	~40 MJ/kg	~20 MJ/m ³
Pollution	Very low SO ₂ , PM	No smoke, but H ₂ S removal needed
Storage	Easy (liquid tanks)	Needs gas storage dome / cylinder

Layout of a Biogas Power Plant

A biogas power plant converts organic waste (such as animal dung, crop residue, food waste, sewage sludge, etc.) into biogas through anaerobic digestion, and then uses the biogas to generate electricity and/or heat.

General Layout / Block Diagram

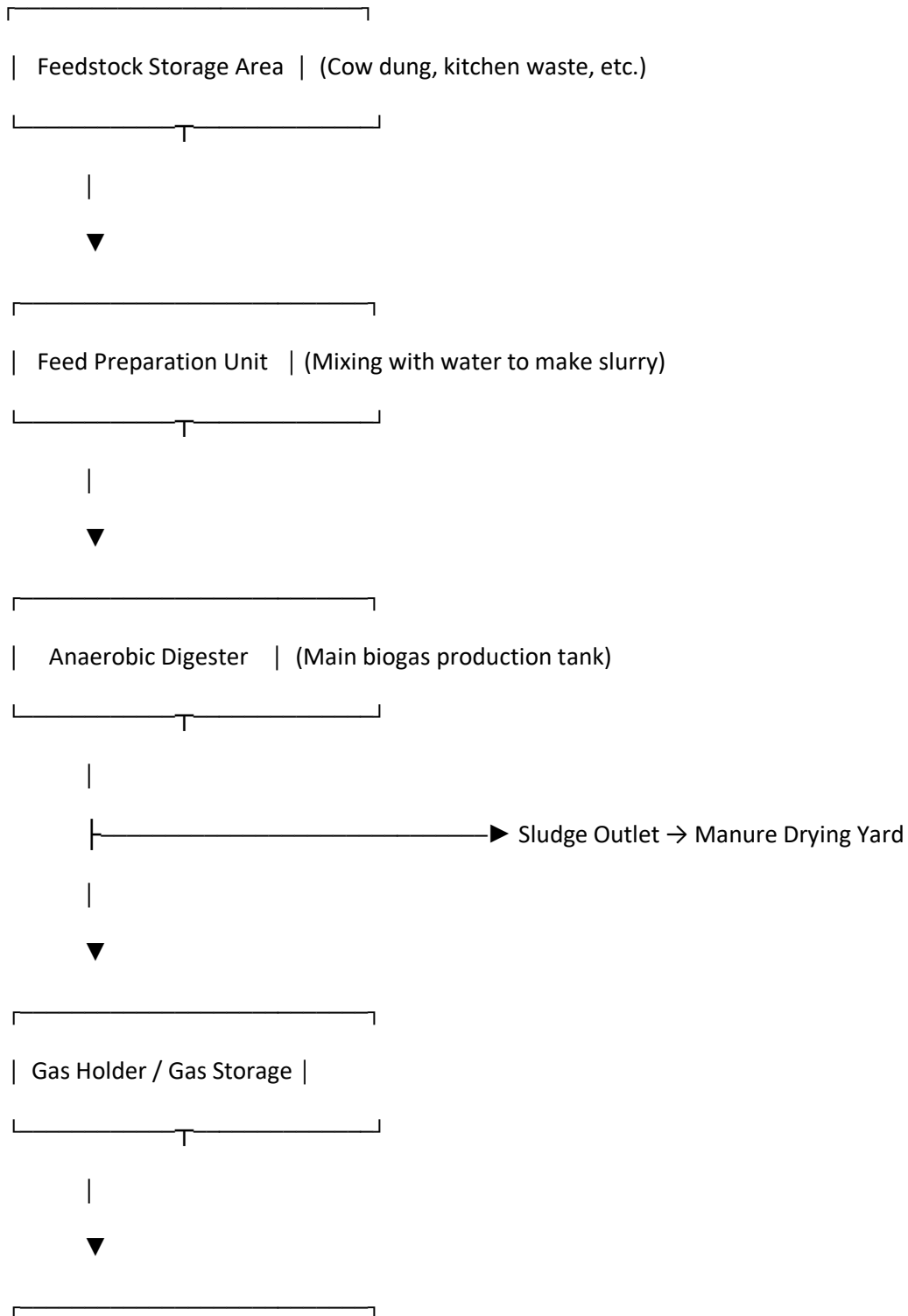

| Gas Purification System | (H₂S, CO₂ removal, moisture removal)

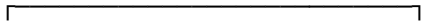
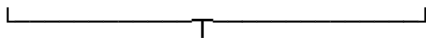

| Biogas Engine / Generator | (Electricity generation)

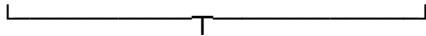

Electricity Output / Grid Supply

Main Components & Functions

Component	Function
Feedstock Storage	Storage of raw material like cow dung, food waste, crop residue, etc.
Mixing Tank	Waste is mixed with water to form slurry (8–10% solid).
Anaerobic Digester	Air-tight tank where bacteria break down organic matter to produce biogas.
Gas Holder / Dome	Temporary storage of biogas produced from digester.
Sludge Outlet	Digested slurry removed and used as organic fertilizer.
Gas Purification System	Removes H ₂ S, CO ₂ , moisture to improve gas quality for engines.
Biogas Engine / Generator	Converts biogas into mechanical power and then electrical power.
Control & Metering System	Controls flow, pressure, and electrical outp

Biogas Composition (Typical)

- **Methane (CH₄):** 50–70%
- **Carbon dioxide (CO₂):** 30–40%
- **Hydrogen sulfide (H₂S):** 0.1–0.5%
- **Moisture & Other gases:** small amount

By-Products

- ✓ **Biogas** → Used for electricity, heat, or upgraded to bio-CNG
- ✓ **Spent Slurry (Bio-fertilizer)** → High in nitrogen, potassium, phosphorus

Applications of Biogas Power Plant

- Rural electrification
- Cooking & heating
- Power for dairy farms, gaushalas, agro industries
- Waste management + fertilizer production

Layout of Thermochemical / Municipal Waste Power Plant

Block Diagram (Text Layout)

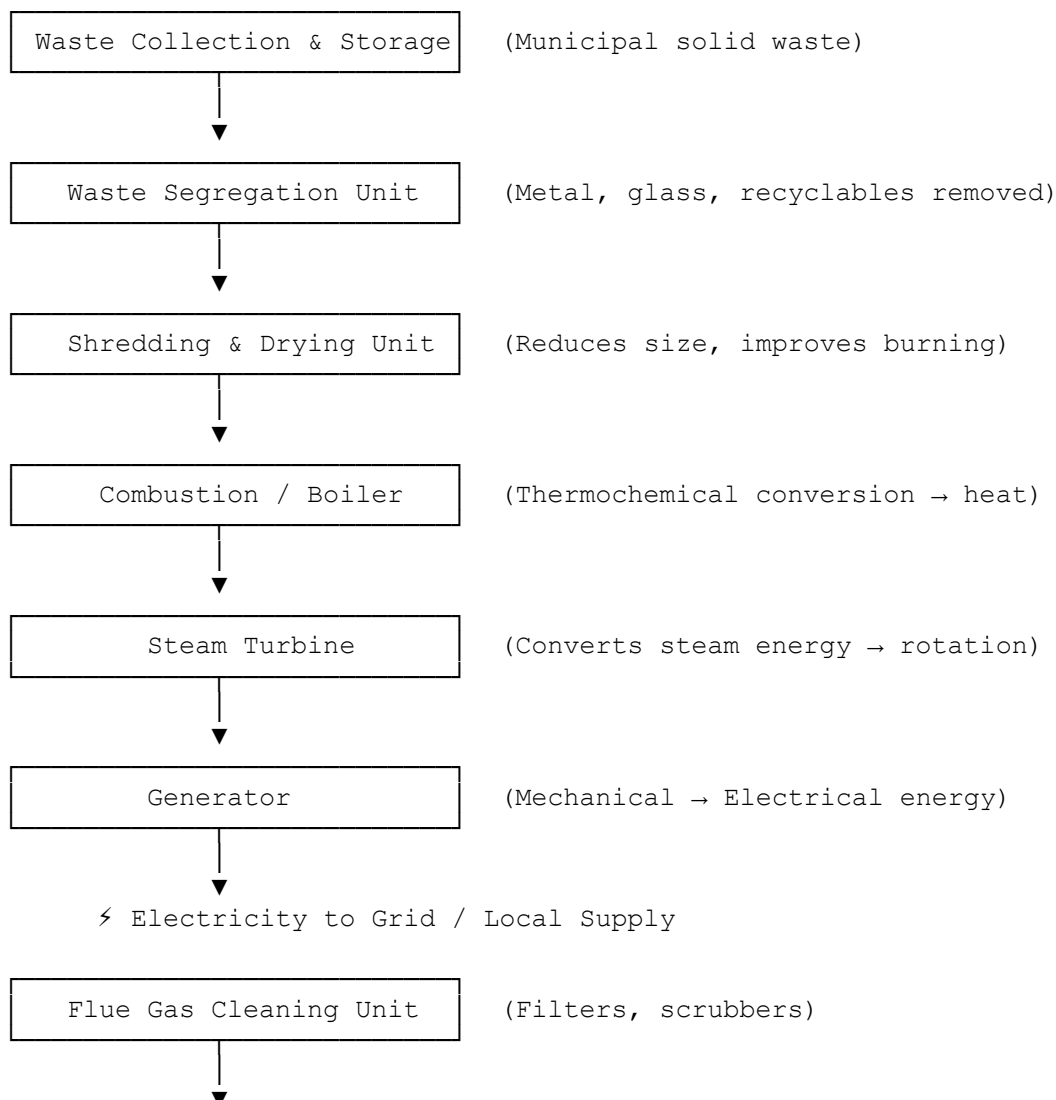

Safe Emission to Atmosphere

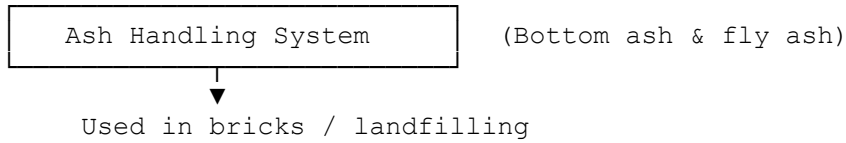

Working of a Thermochemical Waste Power Plant

Waste Collection and Storage

- Municipal solid waste (MSW) collected from households, industries, and markets.
- Stored in **tipping floor or waste bunker** for preprocessing.

Waste Segregation

- Non-combustible materials like **metals, glass, and stones** are separated.
- Recyclable items are removed.
- Remaining combustible portion (plastics, paper, biomass) forms **Refuse Derived Fuel (RDF)**.

Shredding and Drying

- Waste is shredded to uniform size.
- Moisture is reduced by drying or natural aeration to improve combustion efficiency.

Combustion / Thermochemical Conversion

Depending on the plant type, waste is treated by one of the following:

- **Incineration:** Direct burning of waste in a furnace.
- **Gasification:** Waste converted into producer gas (CO, H₂) at 800–1000°C with limited air.
- **Pyrolysis:** Thermal decomposition of waste in absence of oxygen.

In all cases, **heat energy** is released.

Boiler System

- Heat generated from combustion is used to convert water into **high-pressure steam** in a **boiler**

Steam Turbine and Generator

- Steam drives a **turbine**, converting heat energy → mechanical energy.
- Turbine shaft is coupled to a **generator**, which produces **electricity**.

Flue Gas Cleaning System

- Hot gases from combustion pass through:
 - **Cyclone separator**
 - **Electrostatic precipitator (ESP)**
 - **Scrubbers**
 - **Activated carbon filters**
- These remove **dust, SO_x, NO_x, and dioxins** before releasing clean gas into the atmosphere.

Ash Handling

- **Bottom ash** (from furnace floor) and **fly ash** (from flue gas) are collected.
- Used for making **bricks, tiles, or road construction materials**.

Output

- **Electricity:** 500 kWh per ton of waste (approx.)
- **Steam/heat:** Used for district heating or industrial use
- **Residue:** Ash used in construction

- **Advantages**

- ✓ Reduces landfill volume by up to **90%**
- ✓ Generates **renewable electricity**
- ✓ Reduces methane emissions from open dumps
- ✓ Produces useful by-products like **ash** and **steam**

- **Limitations**

- ✗ Requires **proper waste segregation**
- ✗ **High initial cost**
- ✗ Emission control systems are **expensive**
- ✗ **Ash disposal** must be managed carefully

Layout of Agro-Chemical (Bio-Diesel) Power Plant

Block Diagram (Text Layout)

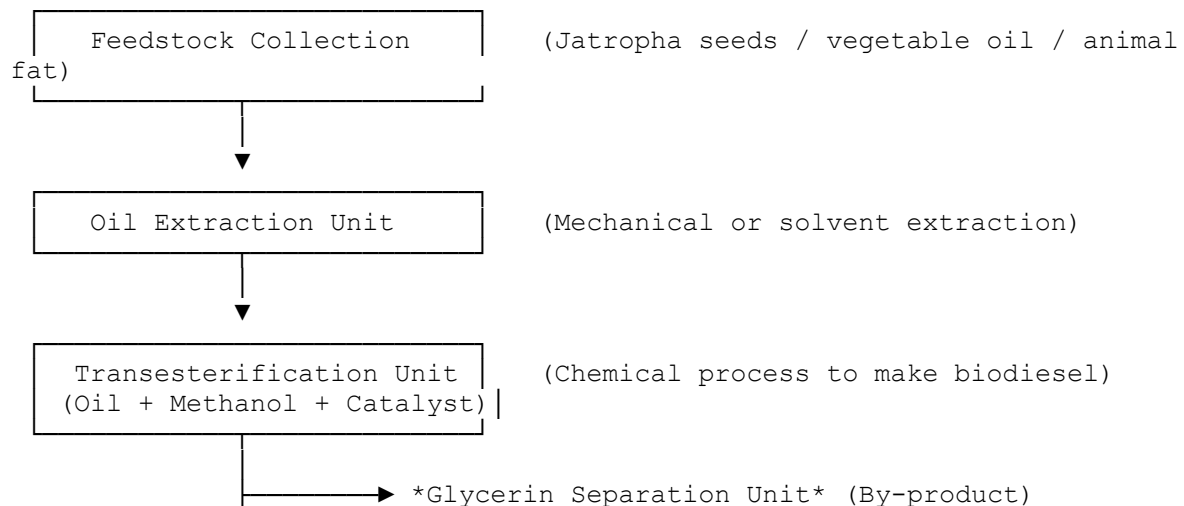

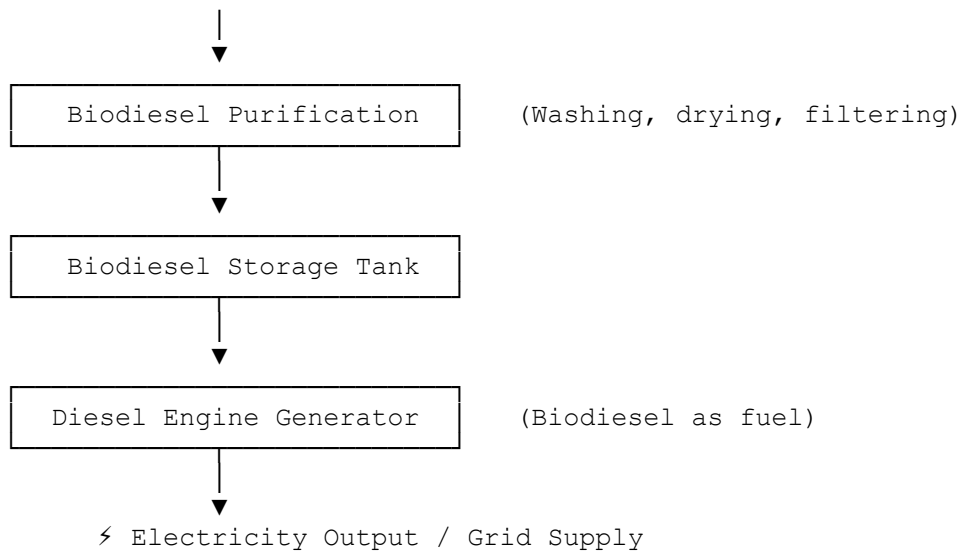

Working of a Bio-Diesel Power Plant

Feedstock Collection

- Feedstock such as **Jatropha, Karanja (Pongamia), Mahua, sunflower oil, or animal fats** are collected from farms or agro-industrial sources.

Oil Extraction

- Seeds are **cleaned, dried, and crushed** in an oil expeller.
- Crude oil is separated from seed cake.
- **Seed cake** is often used as **organic manure** or **animal feed** (after detoxification).

Transesterification Process

- Crude oil is chemically treated to convert it into **biodiesel**.
- The process involves reacting oil with **methanol (CH₃OH)** in presence of a **catalyst** (like NaOH or KOH).

Glycerin Separation

- After the reaction, **glycerin** settles at the bottom.
- **Biodiesel** (methyl ester) floats on top.
- Both are separated:
 - **Biodiesel** → used for power generation
 - **Glycerin** → used in soap, cosmetics, chemical industries

Biodiesel Purification

- Biodiesel is **washed with warm water** to remove impurities (unreacted catalyst, methanol).
- Then **dried and filtered** to obtain pure biodiesel.

Biodiesel Storage

- Purified biodiesel is stored in **storage tanks** before being used as engine fuel.

Power Generation Unit

- Biodiesel is supplied to a **diesel engine coupled to an alternator**.
- The engine burns biodiesel similar to conventional diesel.
- Alternator converts mechanical energy → **electrical energy**.
- Generated electricity is fed to **local load or power grid**.

By-Products Utilization

- **Glycerin:** Used in chemical, soap, and pharmaceutical industries.
- **Oil Cake:** Used as organic fertilizer.
- **Wastewater:** Treated before disposal.

Output

- **Electricity:** Used for rural electrification or grid supply
- **By-products:** Glycerin, seed cake, and heat

- **Advantages**

- ✓Renewable and biodegradable fuel
- ✓Reduces CO₂ and sulfur emissions
- ✓Utilizes non-edible oil crops like Jatropha
- ✓Supports rural economy and farmers

- **Limitations**

- ✗High initial setup cost
- ✗Feedstock supply must be consistent
- ✗Chemical handling (methanol, NaOH) requires care
- ✗Lower cold-start performance in cold climates

Geared Wind Power Plant

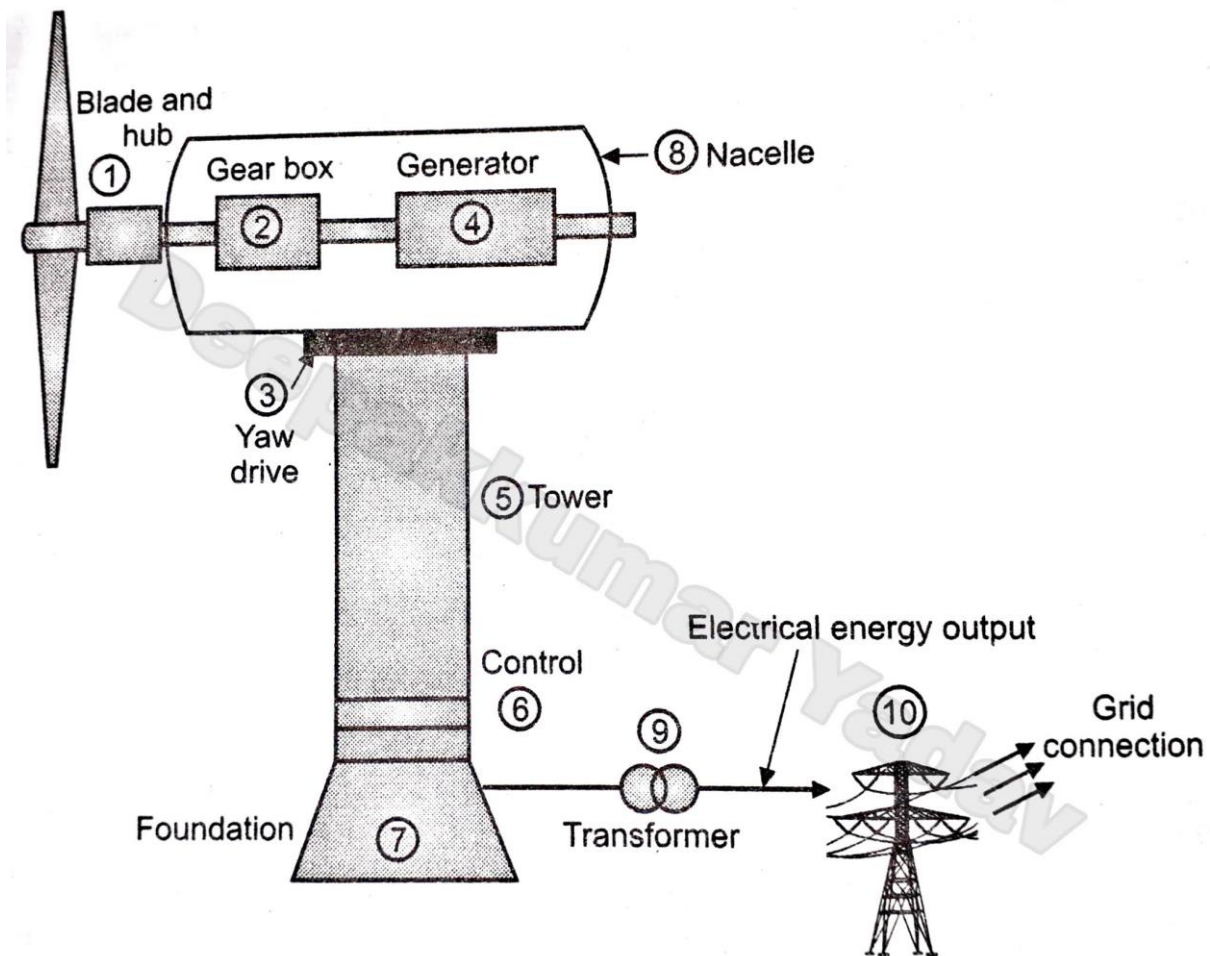

Geared Wind Power Plant

Main components of Gear Wind Power Plant :

1. Blades and hub
 2. Gear box
 3. Yaw drive
 4. Generator
 5. Tower
 6. Control
 7. Foundation
 8. Nacelle
 9. Transformer
 10. Grid connection
- Let us see how these components are assembled

- This is the old and traditional type of plant requiring more maintenance and complex type of design.
- **Design of blades of turbine hub** is more important. Its design takes into account (1) wind speed, (2) desired output power. Accordingly number of

blades, blade orientation, diameter tip speed ratio are designed. Lift-drag characteristics are taken into account.

- **Rotor** : Its blades are strong-durable, light weight and non-corrosive. Composites of reinforced plastic and fibre-glass is used for construction. Rotor design is aerodynamic.
- **Gear box** : It is located in between rotor of blades and the unit of generator. Its design is complicated. Rotor output is amplified by this gear box. It suffers highest stress. Gear box and generator act as a drive-train.
- **Generator** : Variety types of generators are suitable for such type of plant. Turbine rotor rotates the generator which converts rotational energy into electrical energy.

Working of Gear Wind Power Plant :

Wind blow on the turbine blades of turbine starts its rotor, in turn, it drives the generator which produce electrical energy. (Kinetic energy is converted into mechanical energy which is then converted into electrical energy).

Gear box helps in increasing the speed upto 1500 rpm.

Gear box construction is complicated, its consists of many wheels and bearings and requires frequent maintenance.

Advantages of Gear Wind Power Plant :

1. Light in weight.
2. Provides very high torque to turn.
3. It is cheaper in cost.
4. It is able to provide high speed operation which is very economical for the plant.

Disadvantages of Gear Wind Power Plant :

1. Its design is not so simple but is very complicated.
2. Reliability issues arise.
3. Serious damages may occur if any in case of misalignment.
4. So many moving parts, so maintenance work is critical and frequent which involves more cost.

Direct Drive Wind Power Plant

This is also a horizontal axis wind power plant. This type is more reliable and gives better performance as compared with the first type (I.e. geared wind type).

Main components of the Wind Power Plant :

1. Variable speed fixed pitched blades.
2. Wind turbine.
3. Synchronous generator.
4. Rectifier unit
5. Voltage regulator
6. Surplus energy dump
7. D.C. control unit
8. [Inverter](#)
9. Battery
10. Power outputs AC and DC.
11. Assembly of all these components is shown below in the block diagram.

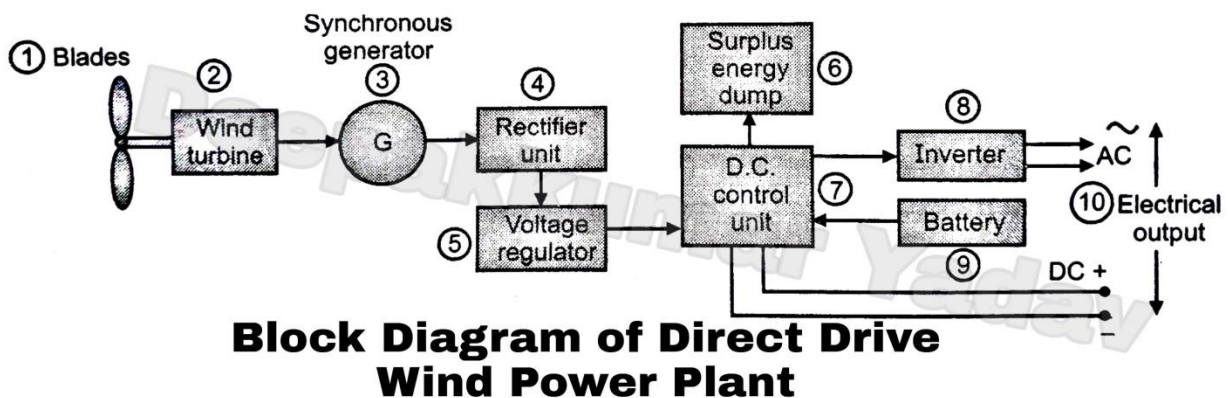

- As compared with previous plant, this plant has no gear-box.
- Turbine blades (1) are very light in weight, made of stiff carbon fibre material. Blades are flat shaped. Due to this shape, lift increases.
- Pitch controller helps blades from high wind forces.
- Wind turbines (2) Wind power rotates blades and therefore rotor of turbine rotates.
- Rotor of turbine rotates generator (G) (3). The generator is permanent magnet synchronous generator.
- Generator (3) converts mechanical power into electrical power.
- Diameter of rotor of generator converts much more power when turning slowly.

- Wind speed-direction data received from sensors, yaw drive turns nacelle to face maximum wind, with the use of 'pitch control blade angle is adjusted as per wind speed.
- Rectifier unit (4) converts AC to DC, voltage regulator (5) regulates output voltage and sends to D.C. control unit (7) from where D.C. supply output power can be fed to DC loads.
- Inverter unit (8) converts D.C. Into A.C. from where A.C. power is the output to be supplied to load (10) or to be connected to grid system.
- Battery (9) is connected to D.C. control unit (7).

Advantages of Direct Drive Wind Power Plant :

1. It has high power to weight ratio.
2. Plant is efficient.
3. Cooling needed is less.
4. More reliable.
5. Better performance.
6. Light weight.
7. Requires less maintenance.

Disadvantages of Direct Drive Wind Power Plant :

1. Transportation problem is more.
2. Needs Improvements in mechanical as well as electromagnetic structure.

Comparison

Feature	Geared Drive Type	Direct Drive Type
Design	Uses a gearbox to increase the speed from the low-speed rotor to a high-speed generator.	Connects the rotor directly to the generator, so the generator rotates at the same speed as the rotor.
Complexity	More complex due to the addition of a gearbox.	Simpler design with fewer moving parts, as there is no gearbox.
Maintenance	Higher maintenance due to gearbox wear, noise, and potential for failure.	Lower maintenance requirements due to the absence of a gearbox.
Cost	Lower initial investment due to established technology and smaller generator.	Higher upfront cost due to the need for a large, specialized generator.

Efficiency	Can be less efficient, especially at lower wind speeds, and losses increase with higher power ratings.	Generally more efficient and reliable, with improved performance, particularly at low wind speeds.
Applications	Suitable for onshore wind farms where maintenance is easier and less expensive.	Preferred for offshore wind farms where maintenance is more difficult and costly.

SQUIRREL CAGE INDUCTION GENERATOR

A Squirrel Cage Induction Generator (SCIG) is a **type of induction machine that operates as a generator when its rotor is driven** faster than the synchronous speed. **It is widely used in wind turbines, small hydro plants, and other renewable energy systems due to its simple construction, ruggedness, and low maintenance.**

In a wind turbine, the rotor blades convert wind energy into mechanical energy, which drives the shaft of a squirrel cage induction generator (SCIG). When the rotor is driven faster than synchronous speed, the machine operates as a generator, delivering electrical energy to the grid.

Construction

The SCIG has the **same construction as a squirrel cage induction motor:**

1. **Stator:**
 - Three-phase winding, similar to that of a motor.
 - Connected to an AC supply or grid.
2. **Rotor:**
 - Made of laminated iron core with **aluminium or copper bars** short-circuited by **end rings** (forms a “squirrel cage”).
 - No electrical connection to the outside circuit.
3. **Shaft:**
 - Driven by a **prime mover** (like a turbine or engine).

Working Principle

When the rotor is driven above synchronous speed (N_s), it induces an EMF in the stator windings.

The machine starts delivering electrical power to the grid. Wind rotates the turbine → turbine shaft drives the generator rotor.

The principle is based on electromagnetic induction.

Condition for generation:

$$N_r > N_s$$

Where:

N_r = rotor speed,

N_s = synchronous speed.

When the rotor speed exceeds N_s , the **slip (s)** becomes **negative**:

$$S = (N_s - N_r) / N_r < 0$$

This negative slip indicates **generator operation**.

The machine now **delivers power** to the grid instead of consuming it.

Advantages

- Simple, robust, and inexpensive.
- No need for DC excitation or slip rings.
- Self-protecting during short circuits or overloads.
- Reliable and long life — ideal for fixed-speed wind turbines.

Disadvantages

- Operates only near **constant speed** (depends on grid frequency).
- Needs **reactive power** (can't self-excite without capacitors).
- Efficiency drops at low wind speeds.
- Not suitable for **variable-speed wind turbines** unless used with a power electronic interface.

Main Points

- Simple, rugged, and low-cost generator.
- Works at nearly constant speed.
- Needs reactive power from the grid or capacitors.
- Suitable for fixed-speed wind energy systems.

Wound Rotor Induction Generator (WRIG)

A **Wound Rotor Induction Generator (WRIG)** is an **induction machine** in which the **rotor has a three-phase winding** (instead of a squirrel cage). It is mainly used in **variable-speed wind turbines**.

Construction

1. **Stator:**
 - Same as a normal induction machine, connected to the grid.
2. **Rotor:**
 - Has three-phase windings connected to **slip rings**.

- External resistors or converters can be connected through brushes and slip rings.

Working Principle

The wind turbine drives the rotor through a gearbox.

When the rotor speed is slightly above synchronous speed, the machine generates electrical power.

The stator supplies power to the grid, and part of the power can also flow through the rotor circuit to control speed and power output.

Control

- By adding variable resistors or using a **power electronic converter** in the rotor circuit, the **speed and power factor** can be controlled.
- This allows **variable-speed operation**, improving energy capture from varying wind speeds.

Advantages

- Variable-speed operation possible.
- Better efficiency and voltage control than SCIG.
- Reduced mechanical stress on turbine and gearbox.

Disadvantages

- More complex and costly than SCIG.
- Requires **brushes and slip rings**, which need maintenance.
- Needs reactive power supply (from grid or capacitors).

Variable-Speed Induction Generator (VSIG)

A **Variable-Speed Induction Generator (VSIG)** is an induction machine that operates at **variable speeds** to generate electricity. It adjusts its **rotor speed** in response to changes in **wind speed**, making it ideal for **wind turbines** and other renewable energy systems.

Working Principle

- The rotor of the induction generator is driven by a **mechanical prime mover** (e.g., a wind turbine).
- The rotor speed can vary, allowing the generator to operate at **different speeds** rather than a fixed speed.
- When the rotor speed exceeds **synchronous speed**, it produces electricity. The **stator** is connected to the grid, delivering power.
- In **wind turbines**, the rotor speed fluctuates based on the **wind speed**, capturing more energy across a range of conditions.

Advantages

- **Better energy capture** over a wide range of wind speeds (compared to fixed-speed systems).
- **Reduced mechanical stress** on the system due to speed variations.
- **Higher efficiency and power quality** in variable-speed wind systems.

Disadvantages

- **More complex** than fixed-speed systems.
- Requires **electronic controls** (e.g., frequency converters) to manage power conversion and grid synchronization.
- **Increased maintenance** due to additional components like converters.

VSIGs are used for **variable-speed generation**, primarily in **wind energy** systems, allowing better efficiency and control compared to fixed-speed generators.

Doubly Fed Induction Generator (DFIG)

A **Doubly Fed Induction Generator (DFIG)** is a special type of **wound-rotor induction generator** used widely in **modern variable-speed wind turbines**.

It allows both the **stator** and the **rotor** to exchange power with the electrical grid — hence the name “**doubly fed.**”

Construction

1. **Stator:**
 - Connected directly to the grid (fixed frequency and voltage).
2. **Rotor:**
 - Has a **three-phase winding** connected to the grid through **slip rings** and a **power electronic converter**.
 - The converter handles only about **25–30%** of total power, making it efficient.

Working Principle

- The **wind turbine** drives the generator at a **variable speed**.
- The **rotor converter** injects or absorbs current to control the **rotor frequency**, allowing the stator output to remain at **constant grid frequency**.
- The generator can operate both **below** and **above synchronous speed** while maintaining stable voltage and frequency.

$$f_s = f_r + f_{slip}$$

where

f_s = stator frequency (grid frequency),

f_r = rotor frequency (controlled by converter).

Operation Modes

1. **Sub-synchronous speed:** Rotor absorbs power from converter.
2. **Super-synchronous speed:** Rotor delivers power back through converter to the grid.

Advantages

- **Variable-speed operation** with constant grid frequency.
- **High efficiency** (converter handles only a fraction of total power).
- **Better control** over active and reactive power.
- **Improved power quality** and **low mechanical stress**.

Disadvantages

- More **complex** and **expensive** than SCIG or WRIG.
- Requires **power electronic converters** and **controllers**.
- **Slip rings and brushes** need maintenance.

Wound Rotor Synchronous Generator (WRSNG)

A **Wound Rotor Synchronous Generator (WRSNG)** is a type of **synchronous machine** where both the **stator** and **rotor** have windings. It operates at a **constant synchronous speed**, making it suitable for applications that require stable voltage and frequency.

Construction

1. **Stator:**
 - Three-phase winding connected to the grid or load (produces output power).
2. **Rotor:**
 - Wound with a DC field winding, supplied by a **DC exciter** or **brushless excitation system**.
 - The DC supply creates a **constant magnetic field**.

Working Principle

- The **prime mover** (e.g., wind turbine or hydro turbine) drives the rotor.
- The DC current in the rotor produces a **magnetic field** that rotates at synchronous speed.
- As the rotor field cuts the stator conductors, it **induces an alternating voltage** in the stator winding.
- The output frequency depends only on the **mechanical speed** and **number of poles**:

$$f = \frac{P \times N}{120}$$

where

f = frequency (Hz),

P = number of poles,

N = speed in rpm.

Advantages

- **Constant voltage and frequency** output.
- **Controllable excitation** (voltage can be adjusted using DC field).
- **High efficiency** and **good power factor** control.
- Suitable for **grid synchronization**.

Disadvantages

- Requires a **DC excitation system**.
- More **complex** and **expensive** than induction generators.
- Needs **precise speed control** for synchronization.

Permanent Magnet Synchronous Generator (PMSG)

A **Permanent Magnet Synchronous Generator (PMSG)** is a **synchronous machine** in which the **rotor magnetic field** is produced by **permanent magnets** instead of a DC field winding. It is widely used in **modern variable-speed wind turbines** and other renewable energy systems.

Construction

1. **Stator:**
 - Contains a **three-phase winding** similar to that of an alternator.
 - Connected to the load or grid through a **power converter**.
2. **Rotor:**
 - Contains **strong permanent magnets** (usually made of neodymium or samarium-cobalt).
 - Produces a constant magnetic field — **no external excitation required**.

Working Principle

- The **prime mover** (e.g., wind turbine) rotates the **magnetized rotor**.
- The **rotating magnetic field** cuts the **stator conductors**, inducing a **three-phase AC voltage**.
- The output frequency depends on the rotor speed and number of poles:

$$f = (P \times N) / 120$$

where

f = frequency (Hz),

P = number of poles,

N = rotor speed (rpm).

Advantages

- **No need for DC excitation or slip rings.**
- **High efficiency** (low losses).
- **Compact and lightweight** design.
- **Better reliability** and **low maintenance**.
- Ideal for **variable-speed operation** when used with a converter.

Disadvantages

- **High cost** due to rare-earth magnets.
- **Demagnetization risk** at high temperatures or faults.
- **Difficult to control** voltage directly (needs converter for grid connection).

HORIZONTAL AXIS SMALL WIND TURBINE

A horizontal-axis wind turbine (HAWT) has blades that spin around a horizontal shaft pointing into the wind.

A **Horizontal Axis Wind Turbine (HAWT)** is the most common type of wind turbine in use.

In the **direct drive type**, the **rotor (blades + hub)** is directly connected to the **generator shaft** — meaning **no gearbox** is used.

This design is simple, efficient, and suitable for **small-scale power generation** (typically below 100 kW).

Major Components

HORIZONTAL AXIS SMALL WIND TURBINE (DIRECT DRIVE TYPE)

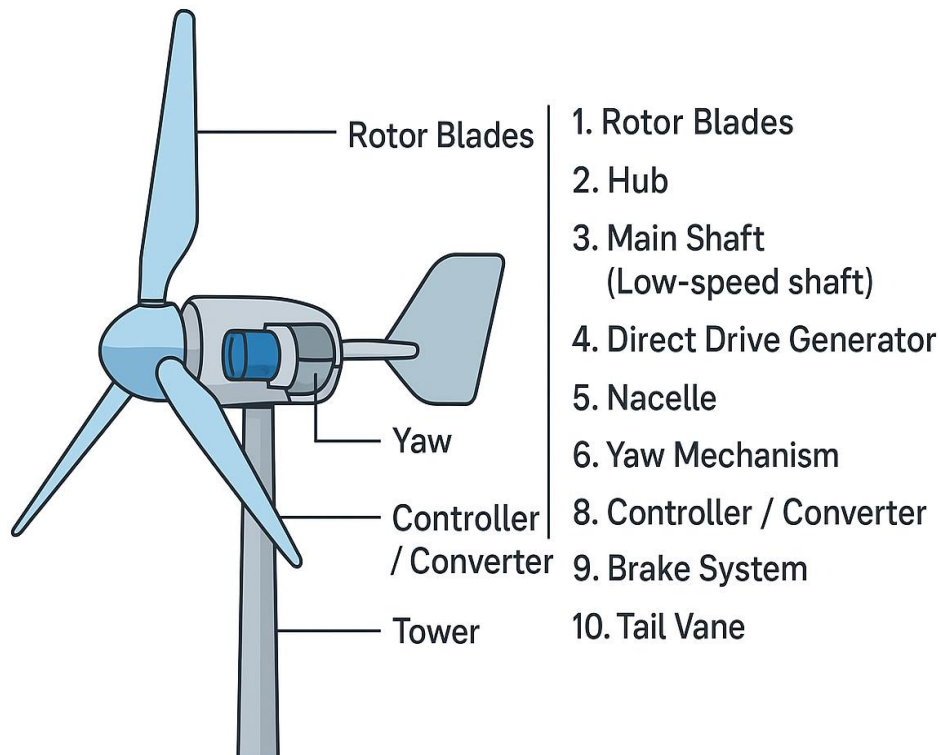

Component	Description / Function
1. Rotor Blades	Capture kinetic energy of wind and convert it into rotational mechanical energy. Usually 2 or 3 blades made of fiberglass or composite materials.
2. Hub	Connects the blades to the main shaft. Transfers torque from the blades to the shaft.
3. Main Shaft	Transmits mechanical power from the hub directly to the generator (since

Component	Description / Function
(Low-speed shaft)	it's direct drive, no gearbox is in between).
4. Direct Drive Generator	Converts mechanical energy directly into electrical energy. Commonly uses Permanent Magnet Synchronous Generator (PMSG) or Squirrel Cage Induction Generator (SCIG) in small systems.
5. Nacelle	Encloses the hub, shaft, and generator at the top of the tower. Protects components from weather.
6. Yaw Mechanism	Keeps the turbine facing the wind direction (automatic in large turbines; manual or tail-vane controlled in small ones).
7. Tower	Supports the nacelle and rotor at a suitable height to access higher wind speeds. Usually made of steel or tubular structure.
8. Controller / Converter	Controls turbine operation, regulates voltage and frequency, and may include a rectifier/inverter for DC or AC output.
9. Brake System	Stops the turbine in high winds or maintenance. Can be mechanical or electrical braking.
10. Tail Vane (for small turbines)	Keeps the rotor aligned with the wind direction automatically.

Working Principle

Step-by-Step Working:

1. **Wind Flow Over Blades:**
 - Wind strikes the **aerodynamically shaped blades**.
 - A **lift force** is created due to air pressure difference across the blade surfaces.
 - This causes the rotor to spin.
2. **Mechanical Energy Generation:**
 - The rotating **hub** turns the **main shaft** directly (no gearbox).
3. **Electrical Energy Conversion:**
 - The shaft is directly connected to the **rotor of the generator**.
 - The generator (usually a **Permanent Magnet Generator**) converts rotational mechanical energy into **electricity**.
4. **Power Conditioning:**
 - The output is often variable frequency/voltage.
 - The **controller or inverter** converts it into usable **AC or DC power** for local use or grid connection.
5. **Yaw and Control:**

- The **tail vane** or yaw system ensures that the turbine always faces the wind direction for maximum efficiency.
- In high wind speeds, braking or blade pitching prevents damage.

Advantages of Direct Drive Type

- No gearbox → **less maintenance and mechanical loss.**
- **Lightweight** and **more reliable** for small wind applications.
- Better efficiency at **low wind speeds.**
- Longer lifespan due to fewer moving parts.
- Quieter operation.

Limitations

- Direct-drive generators are **larger and more expensive** for the same power rating.
- Requires **high-torque, low-speed generator** design.
- Power electronics (inverter/controller) must handle variable frequency output.

Typical Applications

- Rural electrification
- Stand-alone systems with battery storage
- Hybrid systems (solar + wind)
- Remote telecommunication towers
- Small community power supply

Geared Type Horizontal Axis Small Wind Turbine (HAWT)

In a **geared type horizontal axis wind turbine**, the **rotor** drives a **low-speed shaft** connected to a **gearbox**, which increases the speed before transferring it to the **generator**.

This design is common in **medium and small wind turbines** where the generator requires higher RPM to produce electricity efficiently.

Major Components

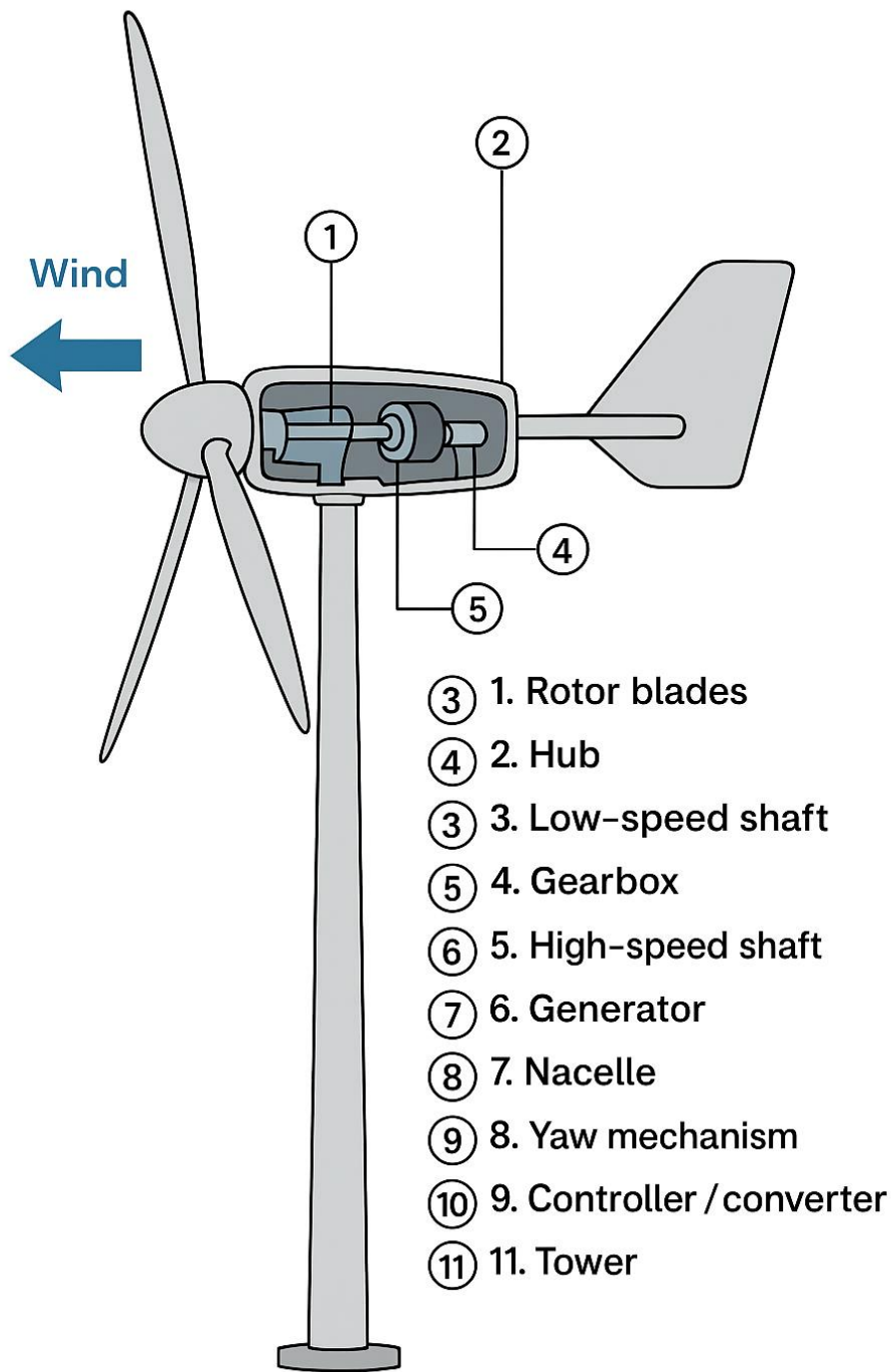

Geared Type Horizontal Axis Turbine

Component	Function / Description
1. Rotor Blades	Capture wind energy and convert it into rotational mechanical energy. Usually 2 or 3 blades made from fiberglass or carbon composites.
2. Hub	Connects the blades to the low-speed shaft and transmits torque.
3. Low-Speed Shaft	Carries the rotational energy from the hub to the gearbox at low speed (typically 20–100 rpm).

Component	Function / Description
4. Gearbox	Increases the rotational speed from the low-speed shaft to the high-speed shaft (ratio ~1:50 to 1:100).
5. High-Speed Shaft	Delivers the high-speed rotation from the gearbox to the generator.
6. Generator	Converts mechanical power into electrical energy. Usually Squirrel Cage Induction Generator (SCIG) or Permanent Magnet Synchronous Generator (PMSG) .
7. Nacelle	Encloses the gearbox, shafts, generator, and brake. Mounted on top of the tower.
8. Yaw Mechanism	Rotates the nacelle so the rotor always faces the wind direction. In small turbines, this can be tail-vane controlled.
9. Brake System	Stops the turbine during maintenance or high wind speeds. Can be mechanical, electrical, or aerodynamic.
10. Controller / Converter	Regulates turbine speed, controls generator operation, and ensures safe and efficient energy output.
11. Tower	Supports the nacelle and blades at a height where wind speed is sufficient.
12. Tail Vane (for small turbines)	Helps orient the turbine into the wind automatically.

Working Principle

Step-by-Step Process:

1. **Wind Capture:**
 - Wind strikes the rotor blades.
 - The aerodynamic lift causes the blades to rotate.
2. **Mechanical Energy Transmission:**
 - The rotating blades turn the **hub** and **low-speed shaft**.
 - The low-speed shaft transfers torque to the **gearbox**.
3. **Speed Amplification:**
 - The **gearbox** multiplies the rotational speed.
 - The **high-speed shaft** then delivers this motion to the generator.
4. **Electricity Generation:**
 - The **generator** converts the high-speed mechanical energy into electrical power (AC).
5. **Power Regulation:**
 - The **controller/converter** regulates voltage and frequency.
 - Power may be stored in batteries or supplied to the grid.
6. **Yaw and Safety Controls:**
 - The **yaw mechanism** keeps the turbine facing the wind.
 - The **brake system** or pitch control stops rotation during strong winds.

Advantages

- **Higher efficiency** for small and medium power ratings.
- Allows the use of **smaller, lighter generators**.
- **Stable power output** due to controlled speed ratio.
- Easier to match generator characteristics to wind speed.

Disadvantages

- Gearbox requires **regular maintenance**.
- **Higher mechanical losses** compared to direct drive.
- More **noise and vibration**.
- Shorter lifespan of mechanical components due to wear.

Applications

- Small-scale electricity generation (1–100 kW).
- Rural or off-grid areas.
- Wind–solar hybrid systems.
- Educational and research installations.

Direct Drive Vertical Axis Wind Turbine (VAWT)

A **Vertical Axis Wind Turbine (VAWT)** has its **main rotor shaft arranged vertically**.

In a **direct drive type**, the rotor is **directly coupled to the generator** without a gearbox.

This setup is ideal for **low wind speed, urban, and small-scale** power generation because it can capture wind from **any direction** and needs **minimal maintenance**.

Major Components

Direct Drive Vertical Axis Wind Turbine (VAWT)

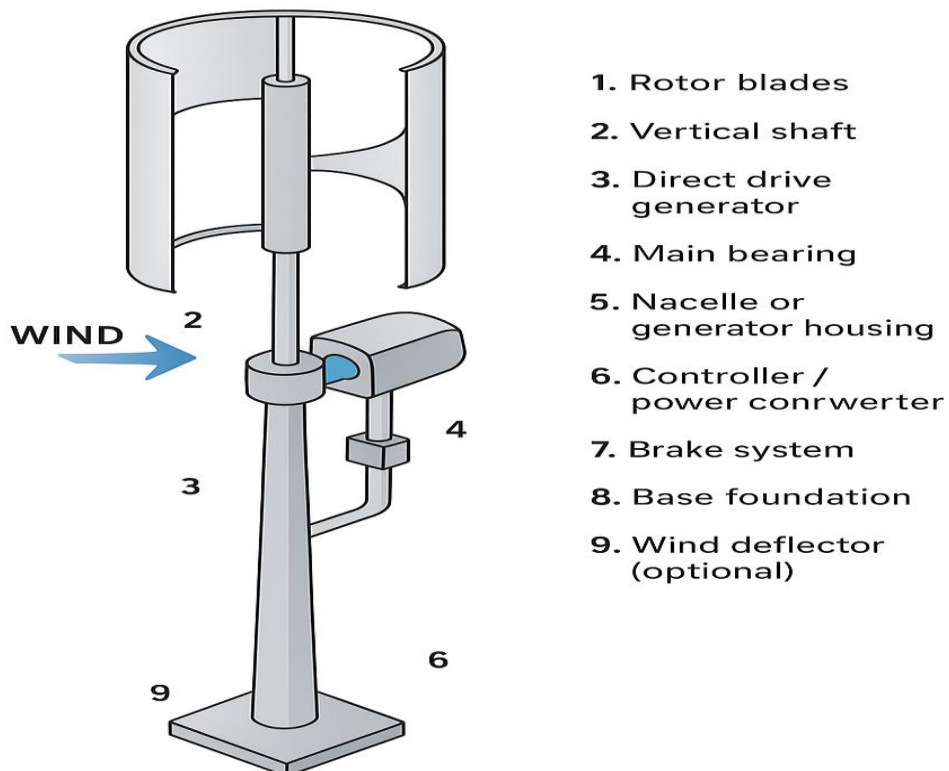

Component	Function / Description
1. Rotor Blades	Capture the kinetic energy of wind and convert it into rotational energy. Two main types: Savonius (drag type) and Darrieus (lift type) .
2. Vertical Shaft (Main Shaft)	Connects the rotor blades to the generator. Transmits rotational mechanical energy directly (no gearbox).
3. Direct Drive Generator	Converts mechanical rotation directly into electrical energy. Commonly uses a Permanent Magnet Synchronous Generator (PMSG) for efficiency.
4. Main Bearing / Support Bearing	Provides smooth rotation and supports the vertical shaft at top and bottom ends.
5. Nacelle / Generator Housing	Protects the generator and mechanical parts from environmental effects. Often mounted near the base for easy access.
6. Frame or Tower	Holds the rotor and generator structure upright. Can be tubular or lattice type.
7. Controller / Power Converter	Regulates electrical output (voltage, current, and frequency) and provides safety control.
8. Brake System	Used to stop the turbine during excessive wind or maintenance. Can be mechanical or electrical.
9. Base Foundation	Anchors the tower securely to the ground for stability.
10. Wind Deflector (optional)	Improves efficiency by channeling airflow toward the blades. Used in some Savonius-type designs.

Working Principle

Step-by-Step Operation:

1. **Wind Energy Capture:**
 - Wind from **any direction** strikes the vertical rotor blades.
 - The blades experience **lift (Darrieus type)** or **drag (Savonius type)** force.
 - This causes the **rotor to rotate** around the vertical axis.
2. **Mechanical Energy Transmission:**
 - The **rotating rotor** drives the **vertical shaft**.
 - Since it's **direct drive**, the shaft is **directly connected** to the **rotor of the generator**.
3. **Electricity Generation:**
 - The **generator** converts this rotational mechanical energy into **electrical energy**.
 - Typically, it produces variable-frequency power depending on wind speed.
4. **Power Conditioning:**
 - The **controller or converter** stabilizes voltage and frequency.
 - Power can then be stored in batteries or supplied to the grid.
5. **Braking / Safety Control:**
 - In high wind speeds, the controller or brake prevents overspeed to protect the turbine.

Advantages

- No need for yaw mechanism (captures wind from all directions).
- Simple **gearless construction** → **low maintenance**.
- **Low noise and compact** design.
- Suitable for **urban rooftops or remote sites**.
- Generator usually located near ground → **easy servicing**.

Limitations

- Lower efficiency than horizontal axis turbines.
- Low starting torque (especially Darrieus type).
- More vibration due to fluctuating aerodynamic forces.

Applications

- Small residential power generation
- Remote communication towers
- Street lighting systems
- Hybrid solar–wind systems
- Educational and research models

Vertical Axis Geared Type Small Wind Turbine (VAWT)

A **Vertical Axis Wind Turbine (VAWT)** has its **rotor shaft oriented vertically**, allowing it to capture wind from **any direction**.

In a **geared type**, the **rotor shaft is connected to the generator through a gearbox** that increases the rotational speed, improving power generation efficiency.

This type is used in **small-scale systems**, especially in **urban** or **low-wind** areas.

Major Components

Vertical Axis Geared Type Small Wind Turbine

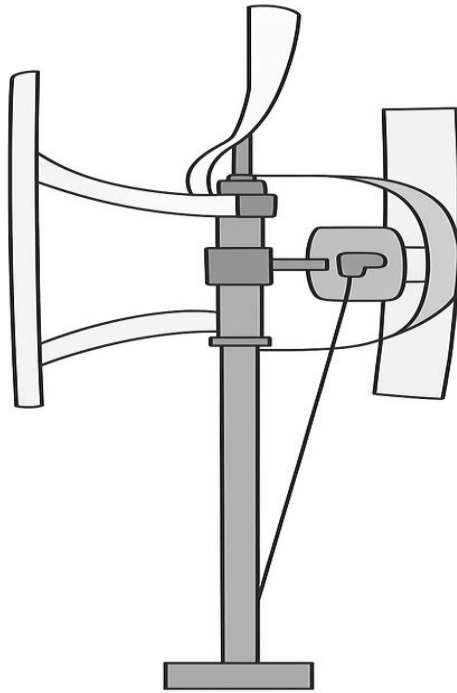

- ① Rotor Blades
- ② Vertical Shaft
- ③ Gearbox
- ④ High-Speed Shaft
- ⑤ Generator
- ⑥ Bearings
- ⑦ Controller/ Power Converter
- ⑧ Brake System
- ⑨ Controller
- ⑩ Nacelle
- ⑪ Base Foundation

Base Foundation

Component	Description / Function
1. Rotor Blades	Capture kinetic energy from the wind and convert it into rotational mechanical energy. Blade designs may be Savonius (drag type) , Darrieus (lift type) , or hybrid .
2. Vertical Shaft (Main Shaft)	Connects the blades to the gearbox. Transmits torque and rotational motion from the rotor.
3. Gearbox	Increases the speed of rotation from the low-speed main shaft to the high-speed shaft that drives the generator (speed ratio typically 1:20–1:100).
4. High-Speed Shaft	Transfers the amplified rotational speed from the gearbox to the generator.
5. Generator	Converts mechanical energy from the high-speed shaft into electrical energy (usually Induction Generator or Permanent Magnet Synchronous Generator).
6. Bearings (Top and Bottom)	Support the vertical shaft and allow smooth rotation, reducing friction.
7. Frame / Tower	Supports the rotor, gearbox, and generator assembly vertically.
8. Controller / Power Converter	Regulates output voltage and frequency; may include inverter for DC to AC conversion.
9. Brake System	Stops or slows down the turbine during high winds or maintenance.
10. Nacelle or Generator Housing	Protects the gearbox and generator from weather and dust.
11. Base Foundation	Provides structural stability and prevents vibration or tipping.

Working Principle

Step-by-Step Process:

1. **Wind Capture:**
 - Wind strikes the **vertical blades**.
 - Aerodynamic or drag forces cause the rotor to rotate around the vertical axis.
2. **Torque Transmission:**
 - The **rotor blades** turn the **vertical main shaft**.
 - The low-speed rotation is transmitted to the **gearbox**.
3. **Speed Amplification:**
 - The **gearbox** increases the rotational speed and transfers it to the **high-speed shaft**.
4. **Power Generation:**
 - The **generator** converts the high-speed mechanical energy into **electrical energy**.
5. **Power Conditioning:**
 - The **controller** smooths the output, converts it to the desired voltage/frequency, and may charge batteries or feed the grid.
6. **Safety and Braking:**
 - The **brake system** or electronic controls prevent overspeed in strong winds.

Advantages

- Works in **all wind directions** (no yaw system needed).
- **Higher output** due to gearbox speed multiplication.
- Compact and **easy to install near the ground**.
- Suitable for **urban or rooftop applications**.

Limitations

- **More mechanical losses** due to gearbox.
- Requires **regular maintenance** of the gearbox.
- Slightly **noisier** than direct-drive type.
- Lower efficiency than large horizontal turbines.

Applications

- Small residential and rooftop systems.
- Streetlight and telecommunication power.
- Rural or off-grid hybrid solar–wind setups.
- Educational and demonstration projects.